

Stampfer RTX 66, RTX 74 & RTX 80D

- sehr robuste Bauweise; wartungsarmes Bein mit Ölschauglas
- 2-faches Treibstofffilter- & 3-faches Luftfilter-System
- Vergaser mit Primerpumpe; geringe Hand-Arm-Vibration
- inklusive Transportrolle
- leistungsstarker Yanmar Dieselmotor (RTX 80D)

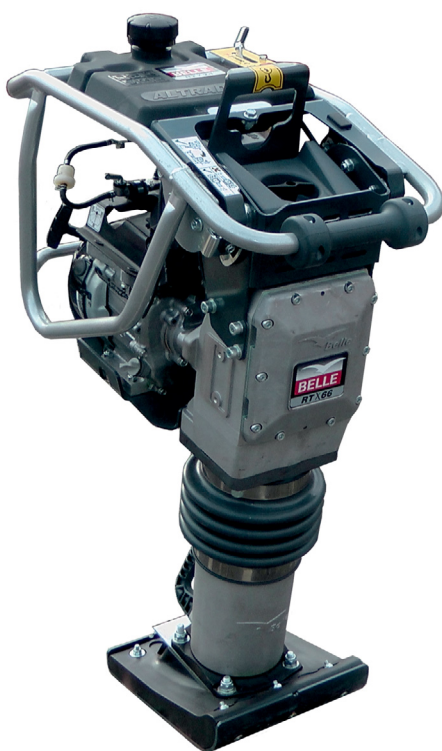

POWERED by
HONDA™



RTX 66, RTX 74 & RTX 80D

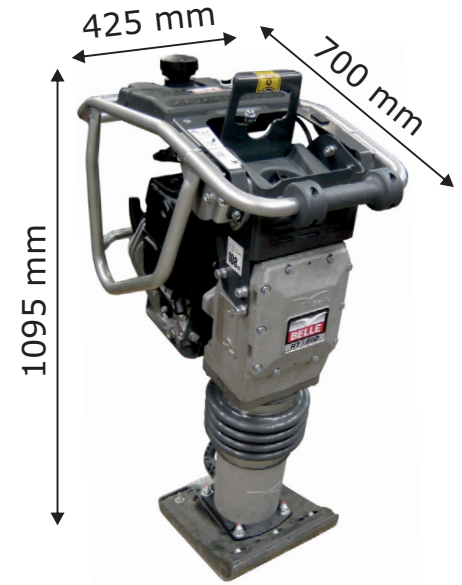
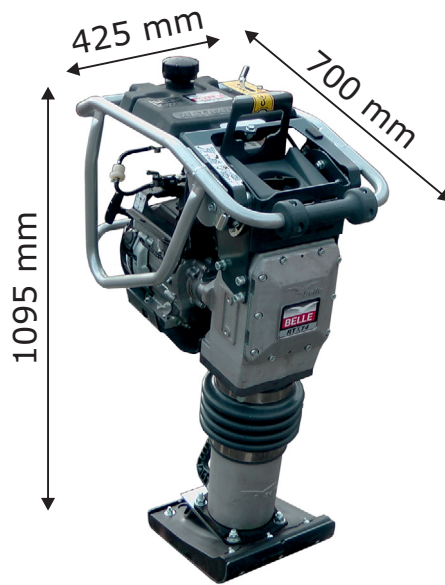
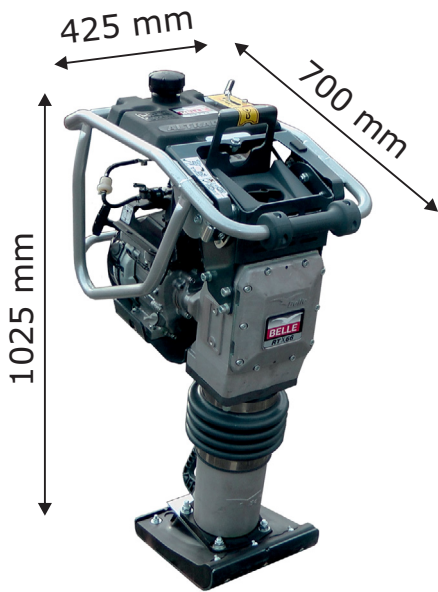

2-faches Treibstofffilter System für eine saubere Kraftstoffzufuhr.



3-faches Luftfilter System für eine hohe Zuverlässigkeit.



Inklusive Transportrolle für einen einfachen Transport.

Stampfer	RTX 66	RTX 74	RTX 80D
Benzinmotor	Honda GX120	Honda GX120	-
Dieselmotor	-	-	Yanmar L48
Leistung	3,5 PS / 2,6 kW	3,5 PS / 2,6 kW	4,7 PS / 3,5 kW
Fuß (L x B)	335 x 280 mm	335 x 280 mm	335 x 280 mm
Schlagkraft	16,5 kN bei 10 Hz	18,6 kN bei 10 Hz	18,6 kN bei 11 Hz
Schläge pro Minute	450 - 600	450 - 600	450 - 600
Hublänge	52 mm	52 mm	52 mm
Tankvolumen	2,5 l	2,5 l	2,5 l
Vibrationspegel	7,60 m/s ²	11,30 m/s ²	11,80 m/s ²
Schalleistungspegel L _{WA}	108 dB (A)	108 dB (A)	108 dB (A)
Gewicht	79,0 kg	84,0 kg	87,0 kg
Artikel-Nr.			
mit 280 mm Kunststoff Fuß	BERTX66H280	BERTX74H280	BERTX80Y280
mit 280 mm Holz Fuß	BERTX66HW280	BERTX74HW280	BERTX80YW280

Technische Änderungen vorbehalten.